

## AJ12 Hanging Type



### SPECIFICATIONS

- \* Voltage: 100/110/120/220/230V, 50/60Hz
- \* Air pressure: 550-800 Kpa
- \* Water pressure: 200-400 Kpa
- \* Net Weight: 270 Kgs
- \* Gross weight: 300 Kgs
- \* Packing dimensions: 1420×1020×1150 mm



#### Unit box & cuspidor

The unit box is 90 degree turnable. It's convenient for the dentist and his/her assistant to operate. The ceramic cuspidor is turnable.



Top mounted instrument tray

### STANDARD CONFIGURATION

- Dental Chair
  - \* With left and moveable right armrests.
  - \* Seamless upholstery.
  - \* Doctor Stool 1pcs.
- Instrument Tray
  - \* Top-mounted or Hanging type instrument tray.
  - \* Two high speed and one low speed handpieces tubes.(2 hole or 4 hole)
  - \* One three-way syringe.
- Assistant Side
  - \* One three-way syringe.
  - \* One Air suction and one saliva ejector.
- Unit Box
  - \* Water heater system.
  - \* Ceramic and moveable cuspidor.
  - \* Turnable unit box.
  - \* Pure water system.
- Cooling light without sensor.
- Controlling System
  - \* One round plastic foot control and one foot panel made of stainless steel.
  - \* One control panel on the instrument tray. (without memory)
- Junction Box
  - \* One junction box for air and water inlet and outlet.

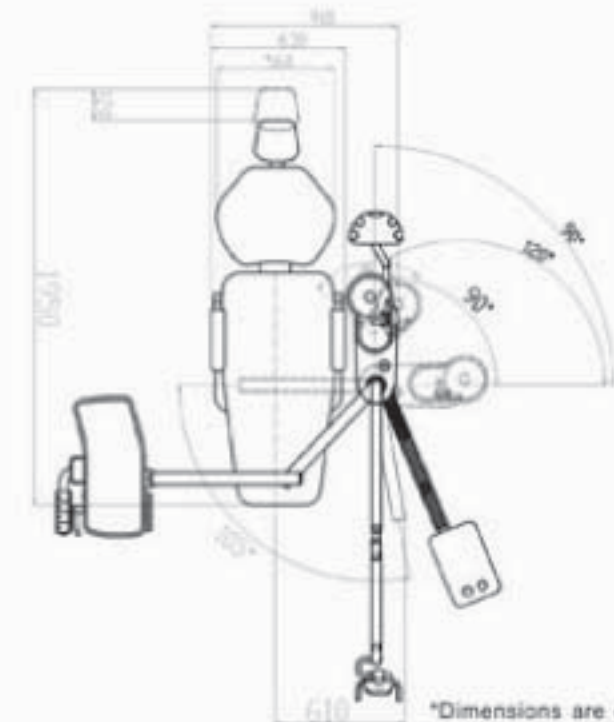
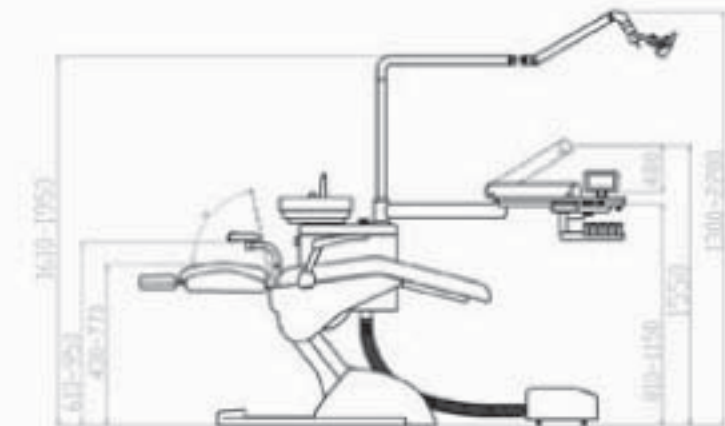

\*Dimensions are quoted in millimetres.